



N-Squared Software N2SRP  
INAP Protocol Conformance Statement

Version 2021-09

# 1 Document Information

## 1.1 Scope and Purpose

This document describes the implementation of the INAP (including CAMEL variants) protocols for real-time SRP flows for voice interaction control using the N-Squared (N2) SIP Specialized Resource Platform (SRP) when used in conjunction with an INAP Service Control Platform (SCP). It should be read in conjunction with the N2SRP Technical Guide [R-1].

This document assumes a working knowledge of the relevant INAP and other telephony concepts, including the standard INAP interactions between an SCP, an SSP, and an SRP (or Intelligent Peripheral).

## 1.2 Definitions, Acronyms, and Abbreviations

Term	Meaning
AC	Application Context (in TCAP)
ARI	Assist Request Instructions
AS	Application Server
ASP	Application Server Process
ASPAC	ASP Active
ASPTM	ASP Traffic Maintenance
ASN.1	Abstract Syntax Notation One
CAMEL	Customized Applications for Mobile Network Enhanced Logic
CAP	CAMEL Application Part
DTMF	Dual Tone Multi-Frequency
ETSI	European Telecommunications Standards Institute
GT	Global Title
GTI	Global Title Indicator
IETF	Internet Engineering Task Force
INAP	Intelligent Networking Application Part
IP	Internet Protocol
ITU-T	International Telecommunication Union Telecommunication Standardization Sector
M3UA	MTP3 User Adaption Layer
MTP3	Message Transfer Part Level 3
N2	N-Squared
OCNCC	Oracle Communications Network Charging & Control
PA	Play Announcement
PACUI	Prompt And Collect User Information
PC	Point Code
RFC	Request For Comments
RI	Routing Indicator
RTP	Real-Time Transport Protocol
SCCP	Signalling Connection Control Part

Term	Meaning
SCP	Service Control Platform
SCTP	Stream Control Transmission Protocol
SIP	Session Initiation Protocol
SLC	Service Logic Controller
SRP	Specialized Resource Platform
SRR	Specialized Resource Report
SSN	Sub-System Number
SSP	Service Switching Platform
SUA	SCCP User Adaption Layer
TCAP	Transaction Capabilities Application Part
TS	Technical Specification

### 1.3 References

The following documents are referenced within this document:

Reference	Document
[R-1]	N2SRP Technical Guide
[R-2]	N2SVCD Technical Guide
[R-3]	N2SRP SIP-SDP-RTP PCS
[R-4]	N2SVCD SIGTRAN-TCAP PCS
[R-10]	ETS 300 374-1 Intelligent Network (IN); Intelligent Network Capability Set 1 (CS1); Core Intelligent Network Application Protocol (INAP); Part 1: Protocol specification

### 1.4 Ownership and Usage

This document, including the information contained herein, is proprietary to N-Squared Software (NZ) Limited but released for informational purposes only.

This document shall not be used or reproduced for any other purpose without the written approval of N-Squared Software (NZ) Limited.

<p><b>N-Squared Software (NZ) Limited</b> PO Box 5035 Terrace End Palmerston North 4410 New Zealand</p>
---

## 2 Contents

1	Document Information .....	2
1.1	Scope and Purpose.....	2
1.2	Definitions, Acronyms, and Abbreviations.....	2
1.3	References .....	3
1.4	Ownership and Usage .....	3
2	Contents.....	4
3	Introduction .....	5
3.1	N2SRP Overview.....	5
4	INAP Compliance.....	6
4.1	INAP Overview .....	6
4.2	INAP Operation Support .....	6
4.3	AssistRequestInstructions.....	7
4.3.1	ReturnError .....	7
4.4	PlayAnnouncement.....	8
4.4.1	Language ID Extension .....	8
4.4.2	ReturnError .....	9
4.5	SpecializedResourceReport.....	9
4.6	PromptAndCollectUserInformation.....	10
4.6.1	ReturnResult .....	10
4.6.2	ReturnError .....	10
5	INAP Message Flows .....	11
5.1	INAP Call Set-Up.....	11
5.2	INAP PlayAnnouncement.....	12
5.3	INAP PromptAndCollectUserInformation .....	12
5.4	INAP Call Tear-Down (BYE from MSC).....	13
5.5	Exception Scenarios .....	13

### 3 Introduction

#### 3.1 N2SRP Overview

The N-Squared Specialized Resource Platform (N2SRP) is a software system for playing audio announcements and collecting DTMF digit input over a SIP/RTP session, under the control of an INAP Service Control Platform (SCP).

A standard N2SRP deployment contains several integration points:

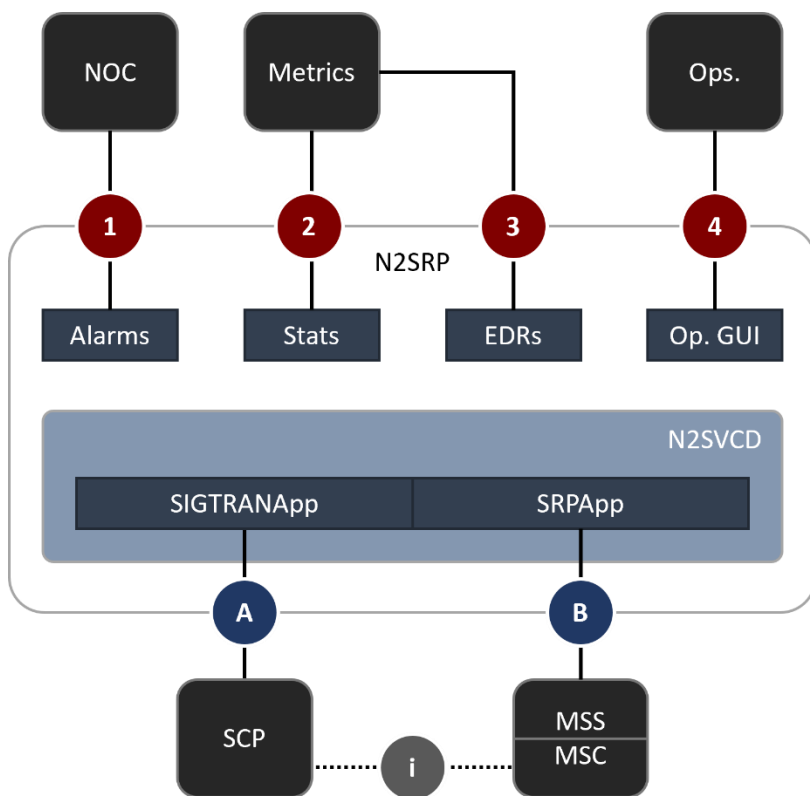

Figure A: N2SRP Integration

This document relates to the N2SRP Compliance for the INAP (or CAP) layer of Interface "A", which has the following stack:

- **INAP (or CAP)**
- TCAP
- SCCP
- SIGTRAN M3UA
- SCTP/IP

This document describes only the uppermost INAP (or CAP) layer. The common N2SVCD Conformance for TCAP and the lower layers of the stack are described in the separate document [R-4].

Conformance is based on the referenced standards or other non-standard functionality but noting that solution conformance to the above is limited to the extent expressly described herein. I.e. statement of conformance to a standard in no way implies conformance to or compliance with the complete standard.

## 4 INAP Compliance

### 4.1 INAP Overview

N2SRP communicates with an INAP SCP to receive instructions for playing announcements and collecting DTMF input. In the mobile environment, the protocol for announcement control may nominally be CAP, although in practical terms there is little difference between CAP and INAP.

N2SRP to SCP interface compliance is formally based on ETSI document "ETS 300 374-1 Intelligent Network (IN); Intelligent Network Capability Set 1 (CS1); Core Intelligent Network Application Protocol (INAP); Part 1: Protocol specification" [R-10]. The N2SRP also supports a small subset of CAMEL parameters and some vendor-proprietary extensions as described herein.

Note that ASN.1 is not a backwards-compatible format. Other non-listed fields received in INAP operations will cause a decode error.

### 4.2 INAP Operation Support

The N2SRP supports only the following INAP operations when communicating with the SCP.

Operation	Direction
AssistRequestInstructions	To SCP
AssistRequestInstructions / ReturnError	From SCP
PlayAnnouncement	From SCP
PlayAnnouncement / ReturnError	To SCP
SpecializedResourceReport	To SCP
PromptAndCollectUserInformation	From SCP
PromptAndCollectUserInformation / ReturnResult	To SCP
PromptAndCollectUserInformation / ReturnError	To SCP

*Table 1: INAP Operations, Results, and Errors*

### 4.3 AssistRequestInstructions

The INAP AssistRequestInstructions (ARI) operation is sent by N2SRP to the SCP when it receives a valid inbound SIP session request.

N2SRP supports sending the following attributes in ARI:

Attribute	Type	Notes
correlationID	Generic Number	Supported as below
.digits	Hex Digits	Extracted from inbound SIP INVITE called party address
.noa	Integer	Nature of Address Set to 2 (unknown)
.nqi	Integer	Number Qualifier Indicator Set to 0 (reserved, dialed digits)
.ni	Integer	Number Incomplete Indicator Set to 0 (complete)
.npi	Integer	Numbering Plan Indicator Set to 1 (ITU-T E.164)
.pri	Integer	Presentation Restricted Indicator Set to 1 (restricted)
.si	Integer	Screening Indicator Set to 0 (user provided, not verified)
iPAvailable	Octet String	Never Present
iPSSPCapabilities	Octet String	Never Present
Extensions	Extensions	Never Present

Table 2: INAP ARI Attributes

N2SRP will extract the called party address from the SIP INVITE, as described in [R-3], expecting a called party in one of the following formats:

- *[fixed-length-routing-prefix]<scp-id>[optional-variable-length-filler]<correlation-id>*
- *[variable-length-routing-prefix]<scp-id><correlation-id>*
- *[variable-length-routing-prefix] <correlation-id><scp-id>*

The *<scp-id>* and *<correlation-id>* values are fixed-length decimal digit values (leading-padded with zero if necessary).

N2SRP will use the *<scp-id>* to determine the SCCP called party address (GT, PC, SSN) as described in the SCCP compliance section. N2SRP will pass the *<correlation-id>* as the ARI *correlationID.digits* parameter. All other ARI operation fields are set to the indicated defaults in *Table 2: INAP ARI Attributes* and are not configurable.

#### 4.3.1 ReturnError

The SCP may send a ReturnError for the ARI. In this case, N2SRP will tear down the call.

## 4.4 PlayAnnouncement

The INAP PlayAnnouncement (PA) operation is sent from the SCP to N2SRP to request N2SRP to play an announcement without digit collection. When the PA is complete, N2SRP will return a SpecializedResourceReport.

N2SRP supports receiving the following attributes in PA:

Attribute	Type	Notes
informationToSend	Choice	Supported
.inbandInfo	Sequence	Supported
.messageID	Choice	Supported
.elementaryMessageID	Integer	Supported
.text	-	Not Supported
.elementaryMessageIDs	Array*Integer	Supported
.variableMessage	Sequence	Supported
.elementaryMessageID	Integer	Supported
.variableParts	Sequence Of	Supported
.integer	Integer	Supported
.number	Octet String	Supported
.time	Octet String	Not Supported
.date	Octet String	Supported
.price	Octet String	Supported
.numberOfRepetitions	Integer	Supported
.duration	Integer	Supported
.interval	Integer	Supported
.tone	-	Not Supported
.displayInformation	-	Not Supported
disconnectFromIPForbidden	Boolean	Must be TRUE (or absent)
requestAnnouncementComplete	Boolean	Must be TRUE (or absent)
extensions	Array/Sequence	As per 4.4.1: Language ID Extension
connectedParty	ConnectedParty	Ignored

Table 3: INAP PA Attributes

### 4.4.1 Language ID Extension

N2SRP supports receipt of a "Language ID" extension for PlayAnnouncement and for PromptAndCollectUserInformation. This mechanism is not part of the ETSI/CAMEL standards, and so the implementation may vary from site to site.

The supported extension container attributes are:

Attribute	Type	Notes
.type	Integer	Supported
.criticality	Enumerated	Ignored
.value	-	Encoding is specified by the individual SCP vendor



Table 4: INAP PA Language ID Extension Attributes

At this time, the only supported encoding is the "NAP" encoding implemented by the Oracle OCNCC SLC (SCP) platform, which is encoded as follows:

- SEQUENCE (Universal)
  - **LanguageID** (Tag=0/Context, Implicit Integer, Mandatory)
  - **Extras** (Tag=1/Context, Implicit Sequence, Mandatory)
    - **Extra0** (Tag=0/Context, Implicit Integer, Optional)
    - **Extra1** (Tag=1/Context, Implicit Integer, Optional)
    - **Extra2** (Tag=2/Context, Implicit Integer, Optional)
    - **Extra3** (Tag=3/Context, Implicit Integer, Optional)

*LanguageID* is mapped to a Language Name internally in N2SRP. The *Extra* fields are ignored.

#### 4.4.2 ReturnError

The N2SRP supports sending ReturnError for PlayAnnouncement as follows:

Value	Error	Supported
7	Missing Parameter	Used when no supported parameter alternatives are present in the PlayAnnouncement
11	System Failure	Used when N2SRP cannot load base configuration
13	Unavailable Resource	Used when the requested message ID or the requested language is unknown, misconfigured, or missing audio

Table 5: INAP PA ReturnError Attributes

#### 4.5 SpecializedResourceReport

N2SRP does not support sending any attributes in SpecializedResourceReport (SRR) operations.

## 4.6 PromptAndCollectUserInformation

The SCP sends INAP PromptAndCollectUserInformation (PACUI) operations to N2SRP to request an announcement with digit collection.

N2SRP supports receiving the following attributes in PACUI, in addition to those supported for PA:

Attribute	Type	Notes
collectedInfo	Sequence	Supported
.collectedDigits	Sequence	Supported
.minimumNbOfDigits	Integer	Supported
.maximumNbOfDigits	Integer	Supported
.endOfReplyDigit	Octet String	Supported
.cancelDigit	Octet String	Supported
.startDigit	Octet String	Ignored
.firstDigitTimeout	Integer	Supported
.interDigitTimeout	Integer	Supported
.errortreatment	Enumerated	Ignored
.interruptableAnnInd	Boolean	Supported
.voiceInformation	Boolean	Ignored
.voiceBack	Boolean	Ignored

Table 6: INAP PACUI Attributes

### 4.6.1 ReturnResult

The N2SRP supports sending ReturnResult for PACUI as follows:

Attribute	Type	Notes
digitsResponse	Generic Digits	Digits entered by end-user.
.digits	Hex Digits	Digits. Any "*" or "#" has been converted to hex.
.scheme	Integer	Numbering Scheme Set to 0 or 1 (BCD even or odd)
.type	Integer	Type of Digits Set to 0 (reserved, account code)

Table 7: INAP PCAUI ReturnResult Attributes

### 4.6.2 ReturnError

The N2SRP supports sending ReturnError for PACUI as follows:

Value	Error	Supported
4	Improper Caller Response	Used when collected DTMF digit string is missing/invalid.
7	Missing Parameter	Used when none of our supported parameter alternatives are present in the PromptAndCollectUserInformation.
11	System Failure	Used when the N2SRP cannot load base configuration.
13	Unavailable Resource	Used when the requested message ID or the requested language is unknown, misconfigured, or missing audio.

Table 8: INAP PCAUI ReturnError Attributes

## 5 INAP Message Flows

In all flows in this section, note that N2SRP may perform call shutdown using TCAP Abort in the case of non-recoverable call error.

### 5.1 INAP Call Set-Up

The following diagram shows the standard INAP operation flow for SRP call setup.

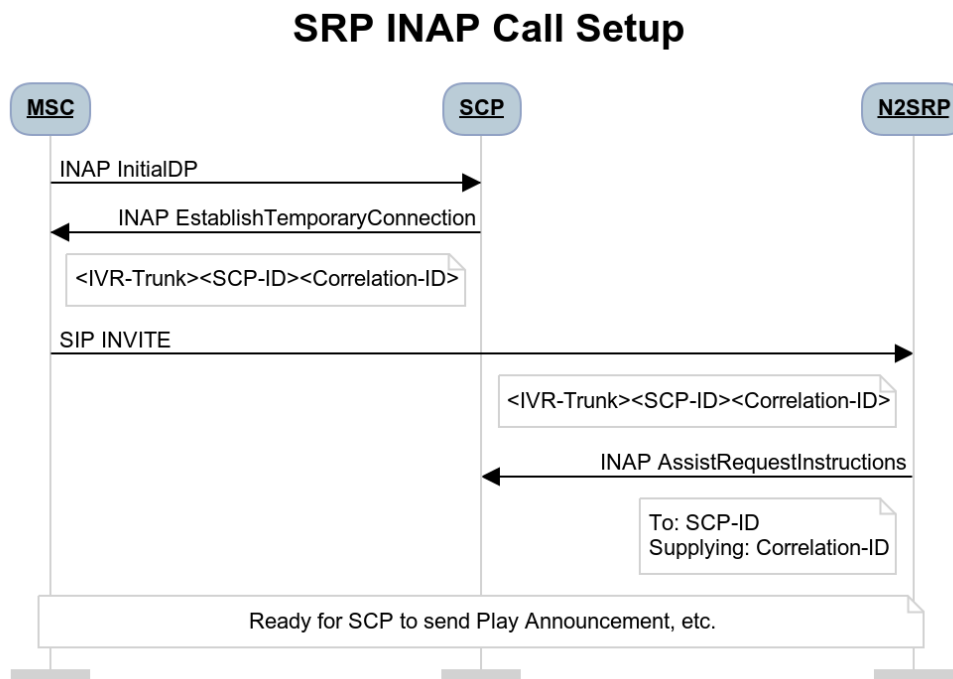

Figure B: SRP INAP Call Setup (ARI)

Note: Confirmation of SIP INVITE is not shown in this diagram.

### 5.2 INAP PlayAnnouncement

The following diagram shows the INAP operation flow for PlayAnnouncement.

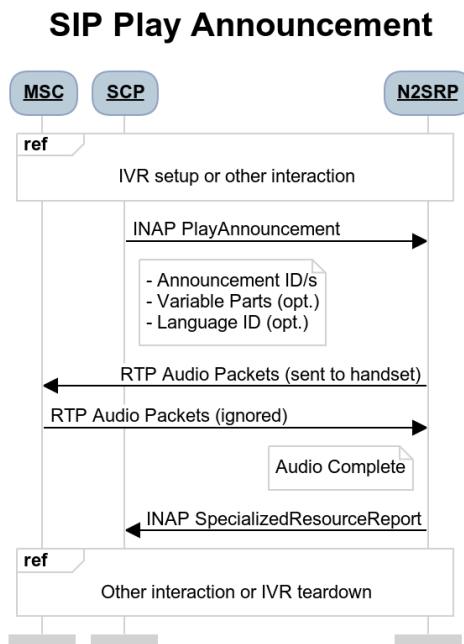

Figure C: SRP INAP Play Announcement (PA & SRR)

### 5.3 INAP PromptAndCollectUserInformation

The following diagram shows the INAP operation flow for PromptAndCollectUserInformation.

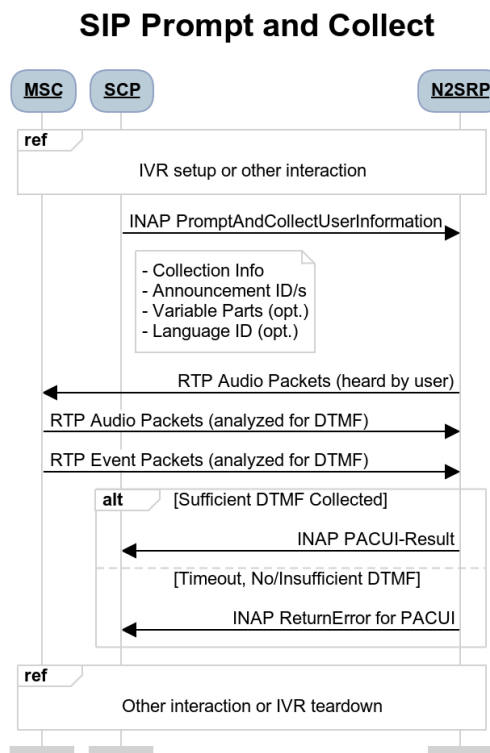

Figure D: SRP INAP Prompt & Collect (PACUI)

### 5.4 INAP Call Tear-Down (BYE from MSC)

When the call is terminated by the SCP at the end of interaction, clean call tear-down of the INAP dialog is performed by pre-arranged end. No INAP messages are sent for call tear-down.

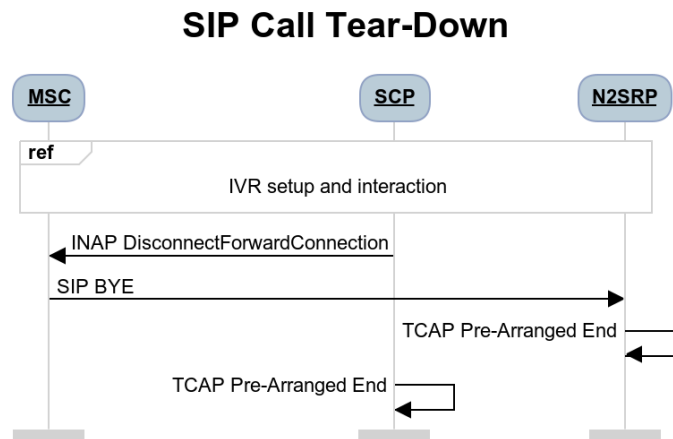

Figure E: SIP INAP Call Tear-Down (BYE from MSC)

Note: Confirmation of SIP BYE is not shown in this diagram.

### 5.5 Exception Scenarios

Various exception scenarios may occur in which TCAP-ABORT and/or SIP BYE are used to terminate all open connections. These scenarios are not shown individually.

Note that like any situation which involves a three-party simultaneous shutdown, race conditions are likely in which one or more end-points may generate an alarm for shutdown of an already terminated (or unknown) connection.